

8' WIDE

7' WIDE

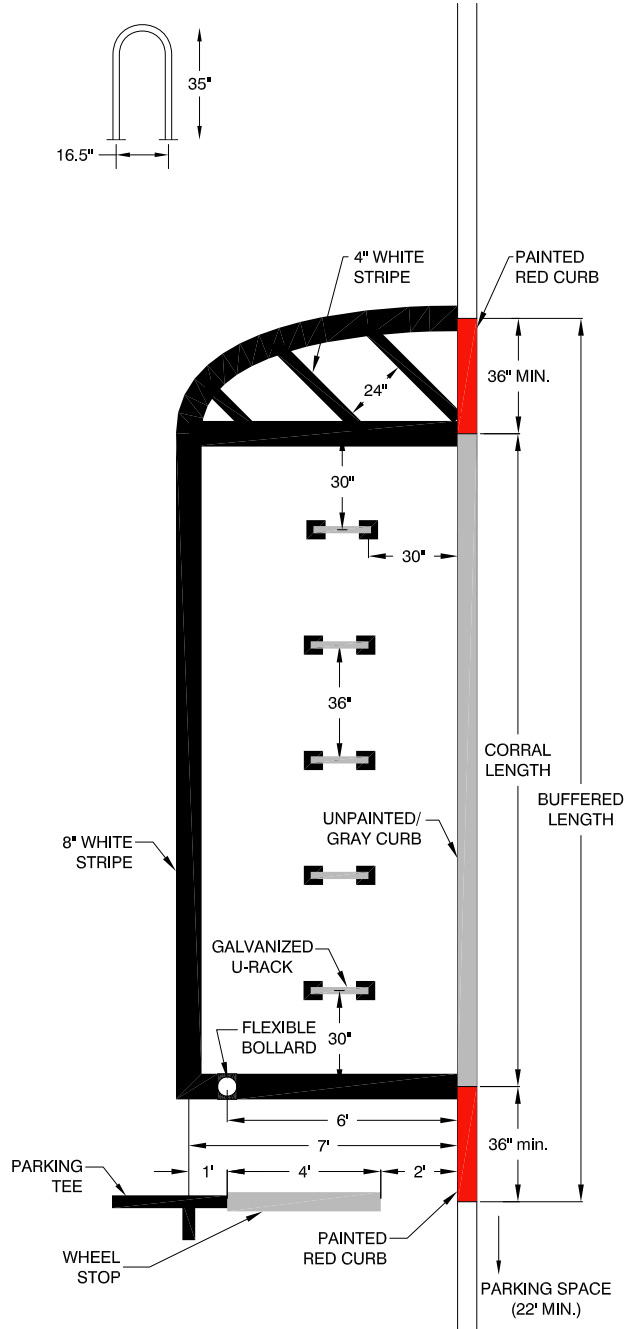
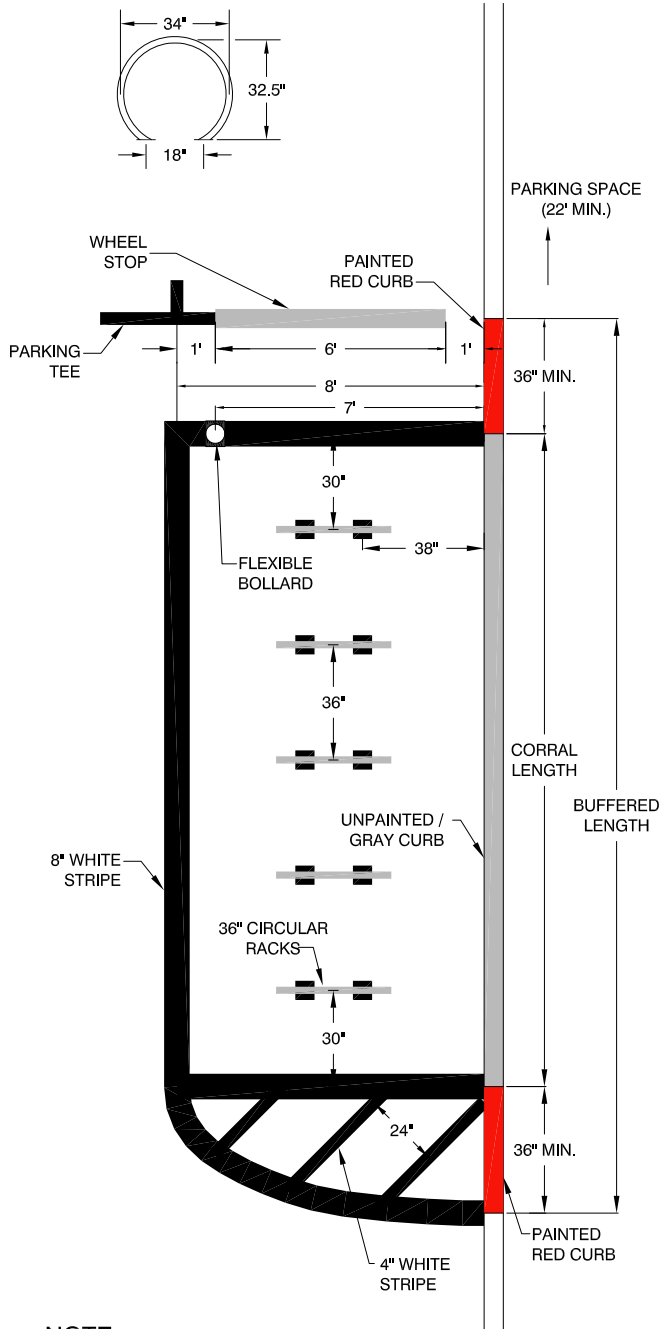

NOTE:

- Corral layout will vary based on the number of racks as well as on site conditions including adjacent lane width, presence of obstructions, location and use of adjacent driveways and crosswalks, etc. When more than the minimum length is available, the design is modified to create longer internal or external buffers, to increase the space between racks, or to install the racks on an angle.
- Angled installation (not shown) will decrease the extension of parked bikes towards the travel lane while requiring more length to maintain the recommended 36" spacing between, and perpendicular to, the racks. See table on page 3.



CITY OF OAKLAND

BUREAU OF ENGINEERING AND CONSTRUCTION
 BICYCLE FACILITIES PROGRAM
 250 FRANK H. OGAWA PLAZA, SUITE 4344 * OAKLAND CA, 94612
 (510) 238-3466 * FAX (510) 238-7415

TYPICAL CORRAL LAYOUTS

SHEET 1 OF 6

BIKE CORRAL DETAILS

SCALE: NTS

DWG. NO.

DATE: JUL 2016

RC-1

CORRAL LOCATION REQUIREMENTS

1. A signed agreement documenting the business or organization responsible for street sweeping and debris removal is required prior to corral installation. (Street sweeping in the corral and along the adjacent curb out to 20 ft in both directions must be performed by hand.)
2. Corrals must be a minimum 50' from a storm drainage inlet to accommodate OPW Hydro-Vac vehicles.
3. Where parallel parking adjoins the corral, the stall should be a minimum of 22' in length.
4. Any rack within the corral must be a minimum of 6' from any fire hydrant and a minimum of 4' away from any in-ground utility covers (manholes, gate pots, etc).
5. Where located at far side of a bus stop, the corral should be placed 15' minimum after AC Transit flag.
6. Racks cannot be installed in asphalt or concrete that is in poor repair, or on roads that are scheduled for paving within 18 months.

BIKE RACK AND CORRAL MATERIALS SPECIFICATIONS

1. In asphalt, multiple racks can be mounted on a single flange (2-4 loops per flange). On concrete, single-loop, flange-mounted racks should be used. Different installation hardware is used for asphalt and concrete installations (see DWG. NO. X-4). All installations will use security anchors in a subset of the mounting holes.
2. In corrals that are less than 8' wide, a 16.5" inverted U-rack should be used. In corrals that are more than 8' wide, a 34" circular rack can be used.
3. A four inch band of white reflective tape must be adhered to the leg of each bike rack loop closest to the travel lane.
4. White delineators shall be Safe-Hit Flexible Channelizer Tubular Marker, Model SH148SMA-WS or equivalent, 40" high, with reflective white tape on both sides of the wand, mounted using 5" lag screws and epoxy on the bottom of the bases and to reinforce the mounting holes (see page 5).
5. Recycled rubber wheel stops shall be 4' or 6' long with white reflective tape, installed to the manufacturer's directions (based on roadway surface type) and reinforced with epoxy in the mounting holes.
6. A reflective, anti-graffiti-coated bike corral sign may be installed on a new pole or electroliter; see page 6.



RACK TYPES: Flange-mounted, square-tube, galvanized steel; U- and circular-styles (shown w/ 4" white reflective tape adhered to the travel lane side of the rack footer).

RECOMMENDED CORRAL EDGE TREATMENTS

Adjoining Feature	Wheel Stop	Flexible Bollard	Buffer Striping
Crosswalk	-	MAYBE	MAYBE
Driveway	-	MAYBE	YES
Intersection	-	MAYBE	YES
Parking Space	YES	YES	-

NOTE: The curb along the length of the corral should be painted gray.



CITY OF OAKLAND

BUREAU OF ENGINEERING AND CONSTRUCTION
BICYCLE FACILITIES PROGRAM
250 FRANK H. OGAWA PLAZA, SUITE 4344 * OAKLAND CA, 94612
(510) 238-3466 * FAX (510) 238-7415

RACK LOCATION REQUIREMENTS AND MATERIALS SPECIFICATIONS

SHEET 2 OF 6

BIKE CORRAL DETAILS

SCALE: NTS

DWG. NO.

DATE: JUL 2016

RC-2

INVERTED U-RACKS

U-Racks (16.5" Flange-to-flange, 24" x 76.5" Parked Bike Footprint)				
Θ	S	W	D	B
0°	36"	76.5"	30"	7.5"
15°	37.5"	74.5"	29.5"	9.5"
25°	39.5"	71.5"	28.5"	12.5"
35°	44"	67"	26.5"	17"
40°	47"	64"	26"	20"
45°	51"	61"	24.5"	23"
Parallel to FC	60"	24"	12"	60"

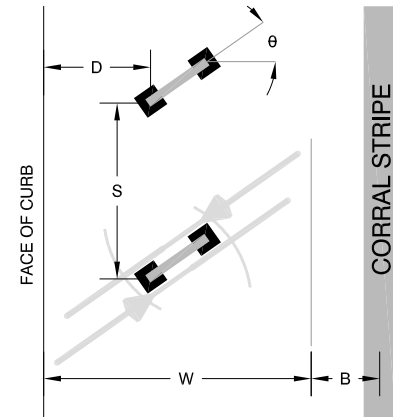

Θ = Rack Orientation angle, in degrees from perpendicular to face of curb.

S = Rack spacing, in inches from center of flange to center of flange, parallel to face of curb.

W = Width of bicycle footprint extension into roadway, in inches from face of curb.

D = Minimum distance from face of curb, in inches from face of curb to center of rack flange.

B = Buffer distance from footprint to corral edge, in inches from extent of bicycle footprint to corral stripe (NOTE: Corrals with U-racks are 7' wide from face of curb to corral stripe).

CIRCULAR RACKS

Circular Racks (18" Flange-to-flange, 24" x 94" Parked Bike Footprint)				
Θ	S	W	D	B
0°	36"	94"	38"	2"
15°	37.5"	91.5"	37"	4.5"
25°	39.5"	87.5"	35.5"	8.5"
35°	44"	81.5"	33.5"	14.5"
40°	47"	77.5"	32"	18.5"
45°	51"	73.5"	30.5"	22.5"
Parallel to FC	76"	24"	12"	72"

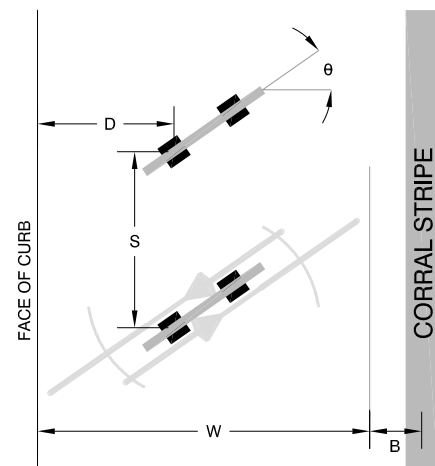

Θ = Rack Orientation angle, in degrees from perpendicular to face of curb.

S = Rack spacing, in inches from center of flange to center of flange, parallel to face of curb.

W = Width of bicycle footprint extension into roadway, in inches from face of curb.

D = Minimum distance from face of curb, in inches from face of curb to center of rack flange.

B = Buffer distance from footprint to corral edge, in inches from extent of bicycle footprint to corral stripe (NOTE: Corrals with circular racks are 8' wide from face of curb to corral stripe).



CITY OF OAKLAND

BUREAU OF ENGINEERING AND CONSTRUCTION
BICYCLE FACILITIES PROGRAM
250 FRANK H. OGAWA PLAZA, SUITE 4344 * OAKLAND CA, 94612
(510) 238-3466 * FAX (510) 238-7415

BICYCLE RACK SPACING GUIDE

SHEET 3 OF 6

**BIKE CORRAL
DETAILS**

SCALE: NTS

DWG. NO.

DATE: JUL 2016

RC-3

ASPHALT ANCHORS (For Single and Multi-Loop Rack Installations in Asphalt)

TOOLS/MATERIALS REQUIRED

- EPX2 grout, 1/2 bag per hole—SEE USER'S GUIDE
- 3/8" SP10 asphalt anchors, one per hole, with bolts and washers
- 2" security bolts, four per rack
- Security bolt socket
- Water
- Masonry drill bit, 6" x 7/8"
- Hammer-drill, hammer, wrench, vacuum-cleaner
- Loctite 262 Mil Spec High Strength Red Threadlocker ("Loctite")

INSTALLATION INSTRUCTIONS

1. Place the rack where indicated. Mark the location of mounting holes.
2. Drill all mounting holes 6" deep, perpendicular to the ground.
3. Clean the holes and surrounding areas using a vacuum cleaner or compressed air.
4. Protect each anchors' thread using the supplied bolt and washer. Hand tighten.
5. Mix the grout with water to a consistency of a syrup. The grout should flow so that it can fill the crevices in the ground around the anchor, but not be too liquid else it will be soaked into the ground.
6. Using the bag as a dispenser, apply the EPX2 grout to the holes, filling each to the top. Allow the grout to flow; refill if necessary.
7. Using a hammer, gently drive each anchor into the ground until the bottom of its washer is flush with the ground.
8. As you lower the anchor, make sure that the grout is visible all the way to the top. Add grout if required.
9. Once the anchors are in place, wash the surface of the roadway to remove the excess grout.
(Once the grout hardens, it will be practically impossible to remove the excess grout.)
10. Allow the grout to harden for about 20 minutes.
11. Mount the rack and secure the washer and bolt to the anchor. Do not exceed the torque allowed for bolt tightening, 200 lbs per inch, per manufacturer's recommendations.
12. Replace four of the supplied bolts with security bolts as shown below.
13. Apply Loctite 262 Mil Spec High Strength Red Threadlocker ("Loctite") to all bolts prior to final tightening.
14. DO NOT SUBJECT THE INSTALLATION TO FULL LOAD FOR 2 HOURS, to allow the grout to cure.

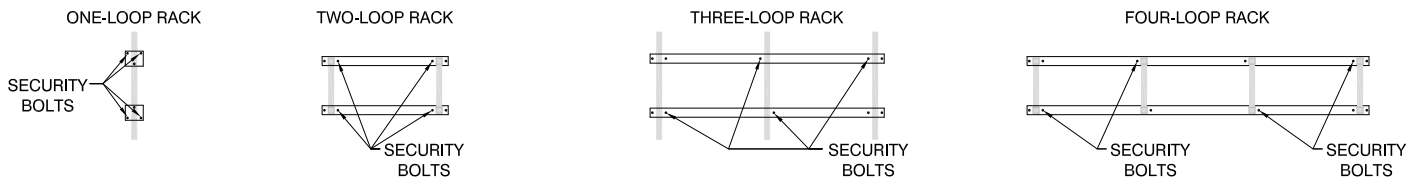

CONCRETE ANCHORS (For Single-Rack Installations in Concrete)

TOOLS/MATERIALS REQUIRED

- 1/2" x 3-3/4" zinc wedge anchors, four per rack
- 1/2" x 2-3/4" zinc rawl spikes, two per rack
- Masonry drill bit, 1/2"
- Hammer-drill, hammer, wrench, vacuum-cleaner
- Loctite 262 Mil Spec High Strength Red Threadlocker ("Loctite")

INSTALLATION INSTRUCTIONS

1. Place the rack where indicated. Mark the location of mounting holes.
2. Drill all holes at least 3-1/2" deep, perpendicular to ground.
3. Clean the holes and surrounding areas using a vacuum cleaner or compressed air.
4. Pound the wedge anchor fasteners in the outer corner holes. The fasteners should protrude 7/8" above the concrete.
5. Place rack over the fasteners. Put the washers and nuts on them. Apply Loctite to exposed threads. Cinch tight with appropriate 3/4" wrench.
6. Pound the Rawl Spikes into the remaining inner holes of the rack.
7. Before the Loctite sets (no more than 10 minutes) tighten the wedge anchors one last time after pounding in rawl spikes.
8. Cut off any length of the wedge anchor protruding more than 1/2" above the nut. If the remaining edge is sharp, file off sharp edges, or apply a dollop of epoxy to the top of the nut.

RACK FOOTPRINT

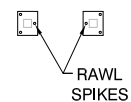

CITY OF OAKLAND

BUREAU OF ENGINEERING AND CONSTRUCTION
BICYCLE FACILITIES PROGRAM
250 FRANK H. OGAWA PLAZA, SUITE 4344 * OAKLAND CA, 94612
(510) 238-3466 * FAX (510) 238-7415

**BICYCLE RACK INSTALLATION
AND HARDWARE**

SHEET 4 OF 6

**BIKE CORRAL
DETAILS**

SCALE: NTS

DWG. NO.

DATE: JUL 2016

RC-4

DELINEATOR (Safe-Hit Flexible Channelizer Tubular Marker, SH148SMA-WS, or Equivalent)

TOOLS/MATERIALS REQUIRED

- Two part, 1011 concrete epoxy, or equivalent
- Delineator (wand, pin-lock base, and locking pins)
- 5" x 3/8" lag bolts
- Masonry drill bit, 6" x 11/32"
- Hammer-drill, hammer, wrench, vacuum-cleaner

INSTALLATION INSTRUCTIONS

1. Clean and dry surface.
2. Mix 5 oz. part "A" and 5 oz. part "B" of 1011 concrete epoxy or equivalent.
3. Apply epoxy evenly to bottom of base.
4. Press base down firmly on surface until a bead of epoxy appears around edge.
5. Allow to cure approximately one hour before installing wand (allow extra time for cold weather).
6. Drill two 5" holes where holes in base are, using 11/32" drill bit.
7. Dip 5" x 3/8" lag bolts into epoxy and insert into base; screw in bolt.
8. Install wand so that flat side faces the direction of traffic.
9. Insert wand and drive locking pins in place with hammer.

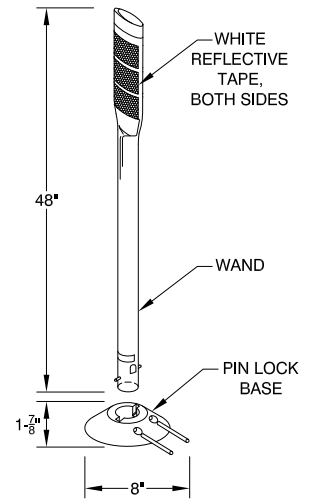

WHEEL STOP

TOOLS/MATERIALS REQUIRED

- Recycled rubber wheel stop, 4' or 6' long, 4" high, black with white reflective tape
- Mounting hardware (18" steel spikes for asphalt, 8" lag bolts and lag anchors for concrete)
- Masonry drill bit (7/16" for asphalt, 3/4" for concrete)
- Hammer-drill, hammer, wrench, vacuum-cleaner

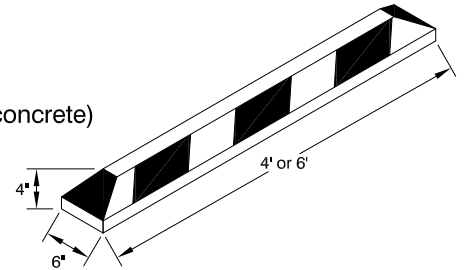

ASPHALT INSTALLATION INSTRUCTIONS

1. Position the wheel stop (block). Using the holes molded in the block as templates, mark the location of each hole on the asphalt surface.
2. Remove the block. Using a high-speed hammer drill with a 7/16" masonry bit, drill a pilot hole at each marked location: a) to avoid fracturing the asphalt with the spike and b) to ease installation. Note: If layer of asphalt is thin, coat each spike with a small amount of activated epoxy resin immediately before driving the spike in place. This will help hold the block flat.
3. Reposition the block so that the molded in holes line up vertically with the drilled pilot holes. Starting with the center hole, hammer the spikes through the block until the head of the spike is snug against the counter bored holes in the parking block. DO NOT DRIVE BEYOND "SNUG"! If driven too far, the spikes or hammer may damage the parking block and will void the warranty.

CONCRETE INSTALLATION INSTRUCTIONS

1. Position the block. Using the holes molded in the block as templates, mark the location of each hole on the concrete surface.
2. Remove the block. Using a high-speed hammer drill with 3/4" masonry bit, drill a 4" to 4 1/2" deep hole at each marked location.
3. Insert a lag anchor (with the large round hole in the anchor facing up) into each hole. Tap the anchor into the holes with a hammer so that the top of each anchor is flush with the surface.
4. Reposition the block so that the molded in holes line up vertically with the drilled pilot holes. Begin with the center hole, applying firm hand pressure.
5. Slip a washer onto a lag bolt, insert the bolt through the hole in the parking block and tighten the bolt about three quarters of the way with a 3/4" socket. Repeat for each hole.
6. Finish tightening each bolt until just snug. DO NOT OVER TIGHTEN! Excessive tightening may damage the parking block and will void the warranty.



CITY OF OAKLAND

BUREAU OF ENGINEERING AND CONSTRUCTION
BICYCLE FACILITIES PROGRAM
250 FRANK H. OGAWA PLAZA, SUITE 4344 * OAKLAND CA, 94612
(510) 238-3466 * FAX (510) 238-7415

**DELINEATOR AND WHEEL STOP
INSTALLATION AND HARDWARE**

**BIKE CORRAL
DETAILS**

SHEET 5 OF 6

SCALE: NTS

DWG. NO.

DATE: JUL 2016

RC-5

ON UNISTRUT POLE

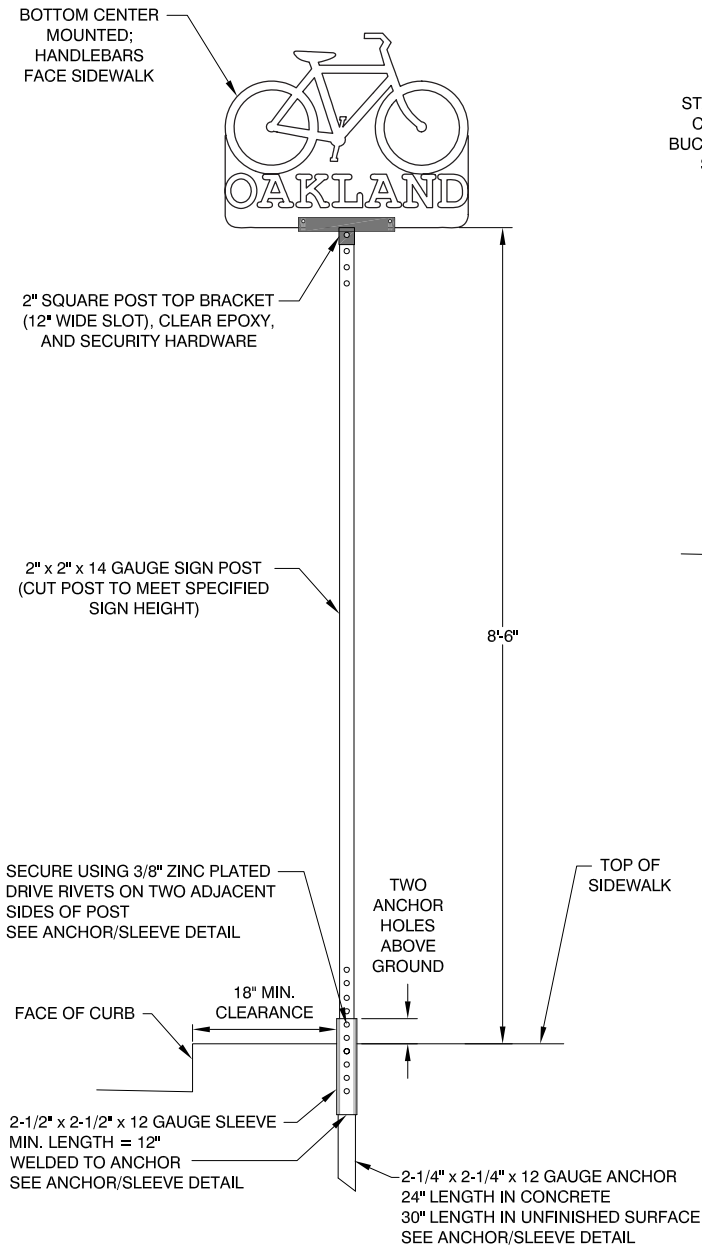

ON ELECTROLIER

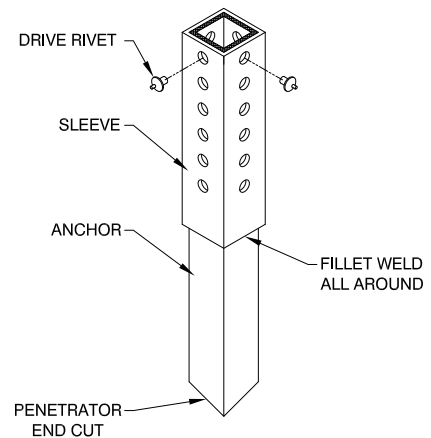
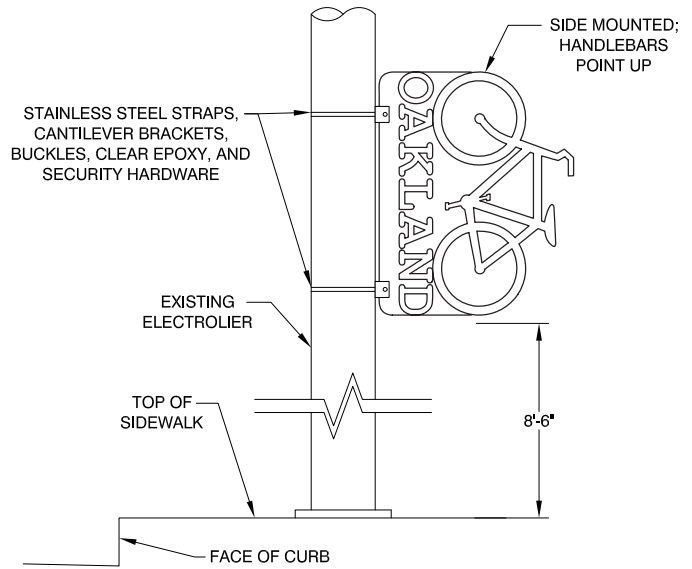

MATERIALS:

1. Sign blade is di-bond, aluminum composite, over a polyethylene core. Drill holes in sign to match bracket.
2. Sign post and anchor/sleeve are galvanized steel.
3. Sign bracket is aluminum.



CITY OF OAKLAND

BUREAU OF ENGINEERING AND CONSTRUCTION
BICYCLE FACILITIES PROGRAM
250 FRANK H. OGAWA PLAZA, SUITE 4344 * OAKLAND CA, 94612
(510) 238-3466 * FAX (510) 238-7415

CORRAL SIGN INSTALLATION AND HARDWARE

SHEET 6 OF 6

BIKE CORRAL DETAILS

SCALE: NTS

DWG. NO.

DATE: JUL 2016

RC-6