



CITY of OAKLAND
OFFICE of PARKS & RECREATION

PARKS AND RECREATION ADVISORY COMMISSION
City of Oakland
Wednesday, December 8, 2010, 4:30 P.M.
Lakeside Garden Center, 666 Bellevue Avenue, Oakland, CA

AGENDA

1. CALL TO ORDER:
2. ROLL CALL:
BELCHER, ENABULELE, HAMMOCK, MATIS, MILLER, MONTAUK, RICARDS, SCOTT, TAYLOR, WONG, WU
3. DISPOSITION OF MINUTES:
 - A. Minutes of November 10, 2010
4. SPECIAL ORDERS:
5. PRAC PENDING LIST:
 - A. Commissioners Report Update, Commissioner Taylor
6. MODIFICATIONS TO THE AGENDA:
7. NEW BUSINESS:
 - A. **Supplemental Report to Tree Permit Appeal, 5890 Birch Court, Priory of Saint Albert the Great:** A supplemental report describing the background and discussion regarding the appeal of a tree removal permit decision at Saint Albert's the Great Priory.
 - B. **Request Approval of the Design of an Off-Leash dog Play Area at Lakeview Park:** The volunteers of the Oakland Dog Owners Group (ODOG) have been working on a redesign of an off-leash dog play area at Lakeview Park in conjunction with the Public Works Agency (PWA), the Office of Parks and Recreation (OPR), and the office of City Council, District 3. The Lakeview Dog Play Area will enclose the corner of the park bordered by MacArthur Blvd to the north and Lakeshore Ave to the southeast. The long-awaited dog play area will contain separate off-leash areas for large and small dogs to exercise and socialize. It is requested that the Parks and Recreation Advisory Commission (PRAC) approve the dog play area redesign.
8. COMMUNICATIONS:
9. PRAC COMMITTEE REPORT:
10. ADVISORY COUNCIL REPORTS:
11. CONDITIONAL USE PERMITS:
12. UNFINISHED BUSINESS:

13. COUNCIL REFERRALS:

14. DIRECTOR'S REPORT:

15. OPEN FORUM:

16. ANNOUNCEMENTS:

17. ADJOURNMENT:

 This meeting is wheelchair accessible. To request materials in alternative formats, or to request an ASL interpreter, or assistive listening device, please call the *Office of Parks and Recreation* at (510) 238-7532 or TDD (510) 615-5883 at least three working days before the meeting. Please refrain from wearing scented products to this meeting so attendees who may experience chemical sensitivities may attend. Thank you.

Next Meeting: *Wednesday, January 12, 2010; 4:30 p.m.*

*Lakeside Garden Center
666 Bellevue
Oakland, CA*



**Public Works Agency
Director's Office**

Memorandum

To: The Honorable Jeffery Taylor, Chair
Parks and recreation Advisory Commission (PRAC)

From: Vitaly Troyan P.E., Interim Director

cc: Brooke A. Levin, Assistant Director
Robert Zahn, Tree Supervisor II

Date: December 8, 2010

Re: Supplemental Report to Tree Permit Appeal, 5890 Birch Court, Priory of Saint Albert the Great

The following is a summary, background, discussion and staff recommendations regarding the appeal of a tree removal permit decision. This appeal is being sent to you pursuant to the Oakland Municipal Code (OMC) Section 12.36.110(C), the Protected Trees Ordinance (PTO), as detailed below.

SUMMARY

At the October 13, 2010 Park and Recreation Advisory Commission (PRAC) meeting it was presented to the Commission that there was an outside donor that was stepping up and would pay for the trimming of the trees. The Commission placed the item on the pending list to provide the parties an opportunity to meet and come to an arrangement that would allow the trees to remain standing while at the same time relieve the Priory of the burden associated with pruning and trimming costs.

The Priory has requested to be placed on the December 8, 2010 PRAC Agenda for further consideration. At this point the Tree Section has not been made aware of any mediation between the Priory and the adjoining/confronting property owners.

Re: PWA/Facilities and Environment – Tree Removal Permit Appeal, Saint Albert's Priory

RECOMMENDATION

The Public Works Agency's recommendation has not changed. It is recommended that the Park and Recreation Advisory Commission:

- Deny the appeal by Saint Albert's Priory;
- Instruct staff to deny tree permit application ND10-069 for 5890 Birch Ct.

Respectfully Submitted,

Vitaly B. Troyan P.E.
Interim Public Works Agency Director

Exhibit:
A - October 13, 2010 PRAC Report



**Public Works Agency
Director's Office**

Memorandum

To: The Honorable Jeffery Taylor, Chair
Parks and recreation Advisory Commission (PRAC)

From: Vitaly Troyan P.E., Interim Director

cc: Brooke A. Levin, Assistant Director
Robert Zahn, Tree Supervisor II

Date: October 13, 2010

Re: Tree Permit Appeal, 5890 Birch Court, Priory of Saint Albert the Great

The following is a summary, background, discussion and staff recommendations regarding the appeal of a tree removal permit decision. This appeal is being sent to you pursuant to the Oakland Municipal Code (OMC) Section 12.36.110(C), the Protected Trees Ordinance (PTO), as detailed below.

SUMMARY

Saint Albert's Priory submitted a tree removal application dated July 22, 2010 to remove ten trees; eight sweet gums, one silver maple and one oak. Tree Services approved the removal of the maple and the oak tree since they were in declining health. The request to remove the eight sweet gums was denied due to community opposition and because pruning would provide a continued healthy status for the trees in question.

An appeal of the decision was filed by Saint Albert's Priory on August 30, 2010 (attached). The basis for the appeal was stated as, "Ongoing concern that trees represent personal and property threat to neighbors' safety." A letter from (Very Rev.) Reginald Martin, O.P. and a Landscape Plan for Saint Albert's Priory were included with the appeal submittal (attached).

BACKGROUND

Tree Services received twenty-two emails opposing the removal of the sweet gums. The opposition came from neighbors living on Chabot Road, Birch Court and elsewhere in the neighborhood. The majority of the comments were that the trees add beauty and aesthetic value to the area. The Tree Services decision was issued on August 24, 2010, approving removal of two trees and denying the removal of eight sweet gums.

Exhibit A – PRAC December 8, 2010 Item 7A

Saint Albert's is concerned with limb failure from the sweet gums. Limbs up to eight inches in diameter have fallen from the trees. Limb failures can be a threat to both Saint Albert's and the single-family home at 6140 Chabot Road that is adjacent to this row of sweet gums (see attached map).

DISCUSSION

Section 12.36.050 of the OMC lists the criteria used to decide if trees should be removed or preserved. Decision making for tree removals is a two-step process:

- First, applications are reviewed to see if they accomplish at least one of the five possible objectives:
 1. To insure public health and safety as it relates to the health of the tree, potential hazard to life or property, proximity to existing or proposed structures, or interference with utilities or sewers.
 2. To avoid an unconstitutional regulatory taking of property.
 3. To take reasonable advantage of views, including such measures as are mandated by the resolution of a view claim in accordance with the view preservation ordinance (Chapter 15.52 OMC).
 4. To pursue accepted, professional practices of forestry or landscape design. Submission of a landscape plan acceptable to the Director of Parks and Recreation shall constitute compliance with this criterion.
 5. To implement the vegetation management prescriptions in the S-11 site development review zone.

- Second, even if the trees qualify for a removal objective, preservation is required if at least one of four possible grounds for denial apply to the situation:
 1. Removal of a healthy tree of a protected species could be avoided by:
 - a. Reasonable redesign of the site plan, prior to construction.
 - b. Trimming, thinning, tree surgery or other reasonable treatment.
 2. Adequate provisions for drainage, erosion control, land stability or windscreen have not been made in situations where such problems are anticipated as a result of the removal.
 3. The tree to be removed is a member of a group of trees in which each tree is dependent upon the others for survival.
 4. The value of the tree is greater than the cost of its preservation to the property owner. The value of the tree shall be measured by the Tree Reviewer using the criteria established by the International Society of Arboriculture, and the cost of preservation shall include any additional design and construction expenses required thereby. This criterion shall apply only to development-related permit applications.

Exhibit A – PRAC December 8, 2010 Item 7A

Tree Services' decision to deny the permit for the removal of the eight sweet gum was based on the criteria that limb reduction work and thinning would reduce the risk of limb failure from the sweet gum trees.

No landscape plan was submitted that explained how many replacement trees would be installed for the sweet gums, the species and size of the replacements. It was a general concept given to city staff during permit processing. The landscape plan that is attached has clear guidelines about what to do on the Saint Albert's property, but it was submitted during the appeal phase of this process and was not available for consideration at the time of permit application. If the plan had been submitted with the application, there would have been more options to consider. Since no plan was submitted at the time of application, Tree Services Section continues to recommend the denial of the eight Sweet gum trees.

Section 12.36.110(C) of the PTO states, "In considering the appeal, the Park and Recreation Advisory Commission shall determine whether the proposed tree removal conforms to the applicable criteria. It may sustain the decision of the Tree Services Section or require such changes or impose such reasonable conditions of approval as are, in its judgment, necessary to ensure conformity to said criteria."

RECOMMENDATION

The Public Works Agency recommends that the Park and Recreation Advisory Commission:

- Deny the appeal by Saint Albert's Priory;
- Instruct staff to deny tree permit application ND10-069 for 5890 Birch Ct.

Respectfully Submitted,

Vitaly B. Troyan P.E.
Interim Public Works Agency Director

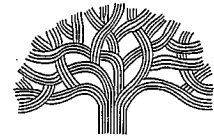

CITY HALL • 1 FRANK H. OGAWA PLAZA • OAKLAND, CALIFORNIA 94612

City Council
Councilmember
District Three

(510) 238-7003
FAX (510) 238-6129
TTY (510) 238-7413

MEMORANDUM

TO: JEFFREY TAYLOR, CHAIR, PARKS AND RECREATION ADVISORY COMMISSION
FROM: NANCY NADEL, COUNCILMEMBER DISTRICT 3
DATE: DECEMBER 8, 2010
SUBJECT: REQUEST APPROVAL OF THE DESIGN OF AN OFF-LEASH DOG PLAY AREA AT LAKEVIEW PARK

SUMMARY

Since 2009, volunteers of the Oakland Dog Owners Group (ODOG) have been working on a redesign of an off-leash dog play area at Lakeview Park in conjunction with the Public Works Agency (PWA), the Office of Parks and Recreation (OPR), and my office (City Council, District 3). We are requesting Parks and Recreation Advisory Commission (PRAC) approval of the dog play area redesign, including a landscape and irrigation plans. The Lakeview Dog Play Area will enclose the corner of the park bordered by MacArthur Blvd to the north and Lakeshore Ave to the southeast. The long-awaited dog play area will contain separate off-leash areas for large and small dogs to exercise and socialize.

FISCAL IMPACT

Funding is available for the Lakeview Dog Play Area in the amounts of \$21,000 from the Public Works Agency's Capital Reserves Fund, \$10,000 from Council District 3 carry-forward Pay-Go funds, \$2,000 from Council District 2, and \$2,000 from the At-Large Council office, for a total of \$35,000. ODOG and my office will work together to seek additional resources, including gifts of services and materials for the construction of the dog play area. ODOG will also seek sustainable resources for operation and maintenance, including the organization of a volunteer program. With the addition of the dog play area, supplementary maintenance to the Lakeview Park by City staff will only include waste removal, application of wood chip cover, and graffiti abatement on dog park signage.

BACKGROUND

The Lakeview Dog Play Area was included in the Lake Merritt Park Master Plan, which was accepted by the Oakland City Council in July 2002, and in the Adams Point Urban Design Plan, submitted to the City of Oakland Community and Economic Development Agency in December 2002. The development of both these plans included extensive public review and comment. Both of the plans included graphic

exhibits showing the dog play area in the location adjacent to MacArthur Boulevard where it is currently proposed.

The creation of a dog play area in the Lake Merritt area was identified as an unmet community need by the Northlake Neighborhood Group (NLNG) in 1998. In 1999, volunteers from ODOG and the NLNG collected 740 petition signatures of residents in the Lake Merritt area, supporting the creation of a dog play area near Lake Merritt. Important factors in selecting a possible location for the dog park included adequate distance from the wildlife sanctuary and low impact on other park user groups and the surrounding community. NLNG met with my office to discuss the dog play area project in December 2001. Councilmembers Chang and Wan held a public meeting on behalf of the dog play area in February 2004. At that time Councilmember Chang offered \$20,000 for the dog play area but the City was not able to commit to building it in time to accept the funds. Thus, Councilmember Chang's funds were used to create the Joaquin Miller dog play area.

Public meetings for the Lakeview Dog Park were also held on November 7, 2005, and on June 29, 2006, and community input from those meetings was incorporated into the design. The meetings were sponsored by Councilmember Nancy Nadel and community outreach was extensive. The needs of other user groups in Lakeview Park, including tot-lot users and soccer players have been addressed in the plans.

In July 2006, the Parks and Recreation Advisory Commission gave one-year probationary support for the construction of a dog play area at Lakeview Park. The creation of the dog play area was conditional upon approval by the City Council to amend the Oakland Municipal Code, Title 6, Chapter 6.04, Article 6.04.080 to include the Lakeview Dog Play Area as an off-leash dog play area in the exempted list of such parks. Unfortunately, the project stalled before the Public Works Department could approve the final design. The delay was in part due to the larger scope of the original dog play area project, which would have required several hundred thousand dollars to construct.

For the past 18 months, volunteers, including design and landscape architects, have worked diligently to scale back the project to meet the City's resource constraints while still fulfilling the design and maintenance requirements of the City. Extensive discussions took place between volunteers and City staff from PWA, OPR, and ADA programs. ODOG also presented to and received approval from the Adam's Point Action Council (APAC) in October 2009. Additionally, my office continues to receive frequent constituent calls and emails requesting a dog play area in this area.

PROJECT DESCRIPTION

To enclose/fence a section of the Lakeview Park for use as an off-lease dog play area for dogs to exercise, and for both dogs and their guardians to socialize.

Specific elements of the project include:

- Separate play areas for large and small dogs
- Fencing to enclose the dog play area, which will be 21,300 sq. ft. total in area. The fence fully separates those on the inside from those on the outside without imposing unnecessary visual impact on the park
- Double gate entries that are ADA accessible with supply vehicle access
- Concrete mow-band around 2/3 of the fence to provide easy access for lawn maintenance
- Two in-ground waste receptacles
- Wood chips to provide the ground cover
- Tree planting between the fence line and MacArthur Blvd

To be determined is whether the project will incorporate Option A or Option B, as described below:

Option A:

Black 4' chain link fencing (waist height) and vine plantings at the fence line

Option B:

5' fencing product similar to Ameristar's Montage Plus Majestic fence recently installed at the Jefferson Square Park Dog Play Area and no vine planting at the fence line

The Lakeview Dog Play Area will enclose the corner of the park bordered by MacArthur Blvd to the north and Lakeshore Ave to the southeast. The dog play area will utilize an area of the park that is under-utilized and where no structures currently exist. Construction of the project will utilize approved on-call Public Works contractors when possible and will go out for bids if elements of the construction require contractors outside of the Public Works on-call list.

KEY ISSUES

We are excited that this project can now move forward with a scaled-down plan that is suitable for the limited financial resource of the City while meeting the design requirements of the Public Works Agency and the Office of Parks and Recreation. Our constituents have been persistent and vocal in advocating for a dog play area near Lake Merritt where many residents and their dogs live in apartments or condominiums with no yard space. Evidence at the City's other dog play areas also show that dog play areas provide a physical space for members of the community to socialize in addition to the benefit afforded to the dogs themselves in the form of exercise. Furthermore, dog play areas require minimum management and maintenance compared to other parks and recreation facilities.

Our office will submit a request to the City Council to amend the Oakland Municipal Code to include the Lakeview Dog Play Area as an off-leash dog play area. Operation of the Lakeview Dog Play Area will also require a stewardship agreement with ODOG for ongoing stewardship.

The following regulations will govern the use of the Lakeview Dog Play Area:

- Dog owners must clean up after their dogs immediately. Always bring a plastic bag
- Limit three dogs per adult
- Small dog area for dogs under 25 pounds and elderly dogs
- Dogs must be leashed to and from fenced area
- Adult handler must be in fenced area with dog at all times
- Keep dogs in sight and maintain voice control
- Children under 16 must be accompanied by an adult
- Dogs must be licensed and have all required shots
- No dogs under four months of age
- No dogs in heat
- Dogs showing repeated aggressive behavior must be leave the park immediately
- No spiked or pinched collars
- No smoking or eating
- Excessive barking must be controlled
- Dog owners shall observe all rules posted in the dog play area

DISABILITY AND SENIOR CITIZEN ACCESS

The working group has included the City of Oakland's Association of Disabled Americans office to ensure the design for the facilities are accessible including accessible path of travel, and gate and landing access.

RECOMMENDATION

I recommend that the Parks and Recreation Advisory Commission approved the revised Lakeview Park Dog Play Area design.

Respectfully submitted,

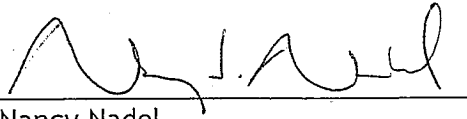
A handwritten signature in black ink, appearing to read "Nancy Nadel", written over a horizontal line.

Nancy Nadel

Attachments: Dog Play Area Design
Landscape Design

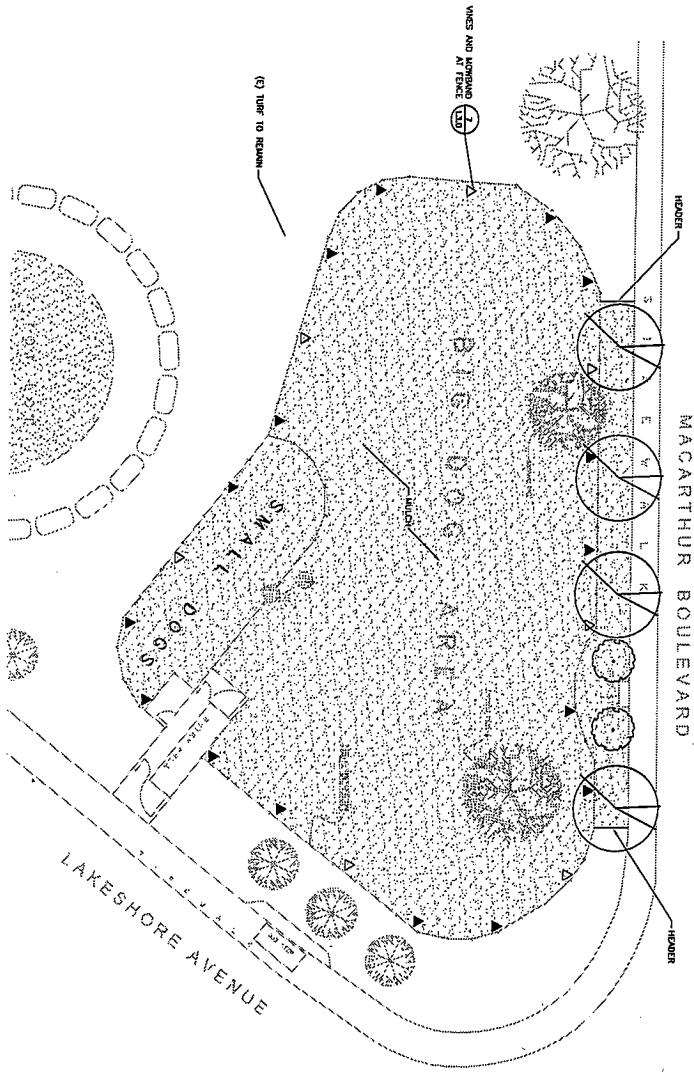

SYMBOL	BOTANICAL NAME	COMMON NAME	PLANTING SIZE	COMMENTS
	TO TREE TO 10' DIAM.		AS SHOWN OR AS SHOWN	
	ASER RIBBUN, FRANCOISIA, KISSA SYLVANIA	RED MAPLE, COLUMBIAN RAIN TREE, TUPALO	AS SHOWN 12" x 12" 12" x 12" 12" x 12"	TO REMOVE TREE SPECIES NOT RECOMMENDED FOR WINTER USE SPECIES NOT RECOMMENDED FOR WINTER USE
	LAGERSTRÖMIA ARBOREA UNKNO	ROSE HEDGE SHAWNEE HEDGE	AS SHOWN 12" x 12" 12" x 12"	ALL SMALL TREES SPECIES NOT RECOMMENDED FOR WINTER USE
	DISCHIDIA BUCCHONIA	VINE WOOD	AS SHOWN 12" x 12" 12" x 12"	TO REMOVE TREE SPECIES NOT RECOMMENDED FOR WINTER USE
	SEMIUM JASMINIDES	PRUNING VINE	12" x 12" 12" x 12"	TO REMOVE TREE SPECIES NOT RECOMMENDED FOR WINTER USE
	WOOD MATCH, 4" KEEP		12" x 12" 12" x 12"	TO REMOVE TREE SPECIES NOT RECOMMENDED FOR WINTER USE

MACARTHUR BOULEVARD

LAKESHORE AVENUE

- PLANTING NOTES**
1. VERIFY LOCATION OF SUBSEQUENT UTILITIES, SPOTS AND SIGNATURES SHOULD BE MAINTAINED OR OTHER WORK NOT SHOWN ON OWNER'S REPRESENTATION. FAILURE TO DO SO WILL HAVE CONSEQUENCES TO THE CONTRACTOR'S SCHEDULE AND COSTS. SUBMITTER TO VERIFY LOCATION OF UTILITIES AND SIGNATURES.
 2. NO PLANT SPECIES SUBSTITUTIONS WILL BE ACCEPTED.
 3. ALL PLANTS AND MATERIALS TO BE APPROVED BY THE OWNER'S REPRESENTATIVE PRIOR TO EXCAVATION OF PLANTING HOLES.
 4. TOPRESS EXISTING FENCED AREA WITH MATCH AFTER TREE REMOVAL AND GRADING. SEE GRADING PLAN BY OTHERS.
 5. NOTIFY OWNER'S REPRESENTATIVE 30 HOURS PRIOR TO REMOVAL OF TREES TO COMMENCE PROJECT OBSERVATION.
 6. REMOVE EXISTING TREE AND REMOVAL TO REMAIN IF DAMAGED BY CONSTRUCTION.
 7. PROTECT EXISTING TREES TO REMAIN.
 8. PLANT VINES AT FENCE POSTS OR CENTER OF FENCE PANEL.



1 VINE IMAGES
SCALE: 1/8"

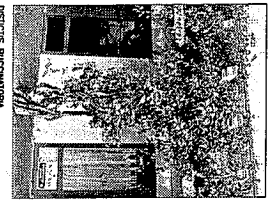

DISCHIDIA BUCCHONIA

FOR PLANTING DETAILS, SEE SHEET L3.0

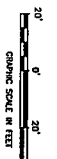

DRAFT

NOT FOR CONSTRUCTION

No.	Scale	Description
1	1"=30'-0"	PLANTING PLAN
2	1/4"=10'-0"	GRADING PLAN
3	1/4"=10'-0"	CONCRETE PLAN
4	1/4"=10'-0"	LANDSCAPE PLAN
5	1/4"=10'-0"	UTILITY PLAN
6	1/4"=10'-0"	FOUNDATION PLAN
7	1/4"=10'-0"	MECHANICAL PLAN
8	1/4"=10'-0"	ELECTRICAL PLAN
9	1/4"=10'-0"	PLUMBING PLAN
10	1/4"=10'-0"	STRUCTURAL PLAN

Lakeview Dog Park
at Lake Merritt
Oakland, CA

PGA design
LANDSCAPE ARCHITECTS
4441 North 4th St
Oakland, CA 94609
1 510 455 1284
F 510 455 1286

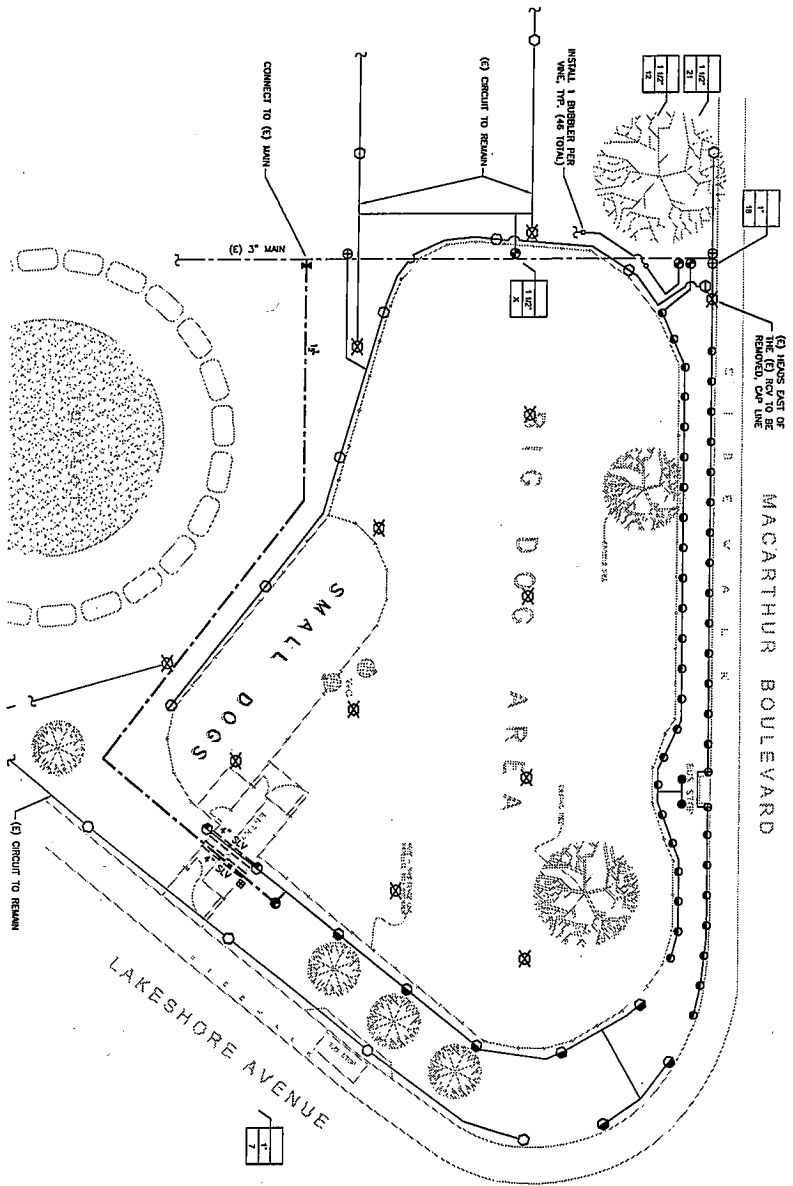

IRRIGATION LEGEND

SYMBOL	MODEL	DESCRIPTION	PSI	GPM	ROUNDS
⊙	180-405-07	NUMBER PFD-UP ROTARY SPRINKLER	50	7.1	50'
⊙	180-40-08-1P3000-18050	NUMBER PFD-UP W/ ROTATOR	40	1.02, 0.88	30'
⊙		EXISTING ROTARY SPRINKLER TO REMAIN			
⊙		REMOVE AND CAP EXISTING ROTARY SPRINKLER TO REMAIN			
⊙	1804-SM-WRS-107-A10	RAIN BIRD PFD-UP LAMIN SPRAY	30	1.56, 0.79, 0.39	10'
⊙	1401	RAIN BIRD PRESSURE COMPENSATING BUBBLER	30	0.25	---
⊙		RAIN BIRD FLEX PFC RISER			
⊙		IRIBO GATE VALVE - LINE SIZE			
⊙	1-113-K	EXISTING REMOTE CONTROL VALVE			
⊙		PEER SERIES			
⊙		BUBBLER REMOTE CONTROL VALVE			
⊙	23 DWP	RAIN BIRD QUICK COUPLING VALVE			
---		MANHOLE: SCH 40 PFC SOLVENT WELD PIPE WITH SCH 40 PFC SOLVENT WELD FITTINGS. ALL MANHOLE TO BE PURPLE IN COLOR AND BEARING BEARING MANHOLE SYMBOLS RECYCLED W/HD W/ MANHOLE SYMBOLS.			
---		(E) MANHOLE			
---		LATERAL LINE: CLASS 200 PFC SOLVENT WELD PIPE WITH SCH 40 PFC SOLVENT WELD FITTINGS. ALL MANHOLE TO BE PURPLE IN COLOR AND BEARING BEARING MANHOLE SYMBOLS RECYCLED W/HD W/ MANHOLE SYMBOLS.			
---		(E) LATERAL LINE			
---		SLEEVE: SCH 40 PFC, SIZE AS NOTED ON PLAN.			
---		CONTROLLER / STATION NUMBER-COMMUNE: CIRCUIT NUMBERING WITH OPEN STATIONS ON (E) CONTROLLER			
---		APPROXIMATE GPM THROUGH VALVE			

LATERAL PIPE SIZING

CALLERS PER MINUTE	PIPE SIZE (SCH. 40)
0 - 8 GPM	3/4" PIPE
9 - 13 GPM	1" PIPE
14 - 22 GPM	1-1/4" PIPE
23 - 30 GPM	1-1/2" PIPE
31 - 50 GPM	2" PIPE

SUPPLEMENTAL ABBREVIATIONS

DBM CALLING FROM MANHOLE
RCV REMOVE CONTROL VALVE
SCH SCHEDULE
SLV SLEEVE

FOR IRRIGATION DETAILS, SEE SHEET L3.0

IRRIGATION NOTES

- IRRIGATION SYSTEM DESIGN IS 30 GPM AT 70 PSI MINIMUM STATIC PRESSURE. PRESSURE AT START OF WORK, HIGHER OWNER'S REVIEW. PRESSURE AT STATIC PRESSURE IS LOWER THAN STATED REMOVE.
- HAVE IRRIGATION POINT OF CONNECTION AS SHOWN ON PLAN. REVIEW PROVISION CONNECTIONS TO AND FROM EXISTING MAINS WITH CITY REPRESENTATIVE PRIOR TO INSTALLATION.
- COORDINATE WITH CITY REPRESENTATIVE TO RE-USE AVAILABLE CIRCUITS ON (E) CONTROLLER. MAKE ALL CONNECTIONS.
- THE PROPOSED PLAN IS CONSIDERING AND PART OF THE BE SHOWN IN PLANNING AREAS FOR DESIGN CLIENT. UNLESS ALL OTHERWISE SHOWN ON PLAN.
- FULL COVERAGE IS REQUIRED. HAVE LAIR OPERATIONS TO LAYOUT AS REQUIRED TO OBTAIN COMPLETE COVERAGE AND REVIEW WITH OWNER'S REPRESENTATIVE.
- SELECT SPRAY NOZZLES TO FIT AREA BEING IRRIGATED AND TO MATCH DESIGNER'S INTENT.
- INSTALL SPRAY STRAY HEAD ON 6" PFD-UP BODY. REVIEW WITH OWNER'S REPRESENTATIVE.
- INSTALL CHECK VALVES ON LATERAL LINES AS REQUIRED TO PREVENT LOW HEAD DRAINAGE.
- VERIFY THAT PRESSURE REGULATING DEVICES ARE PROVIDED WITH ALL SPRAY NOZZLES. REFER TO MANUFACTURER'S INSTRUCTIONS FOR SPECIFIC REQUIREMENTS FOR SHORT DURATION SPRAY NOZZLES.
- AND/OR TRENCHING WITHIN RIP LINE OF EXISTING TREES, WHERE TRENCHING WITHIN RIP LINE IS UNAVOIDABLE REVIEW WITH OWNER'S REPRESENTATIVE. REFER TO MANUFACTURER'S INSTRUCTIONS FOR SPECIFIC REQUIREMENTS FOR SHORT DURATION SPRAY NOZZLES.
- INSTALL PIPE AND WIRE UNDER PAVING IN PFC SCH. 40 SLEEVE WITH 18" COVER.
- INSTALL (E) 1/2" BUBBLER ON FLEX RISER AT EACH NEW WIRE ALONG FLEX.

NOT FOR CONSTRUCTION

Lakeview Dog Park at Lake Merritt Oakland, CA

IRRIGATION PLAN

DATE: 7/21/2010
SCALE: 1"=20'-0"
SHEET: 01
OF: 01

L2.0

PEA design®
444 13th Street
Oakland CA 94612
1 510 425 1284
1 510 425 1285

LICENSED PROFESSIONAL ENGINEER
STATE OF CALIFORNIA
No. 45887
CIVIL ENGINEER

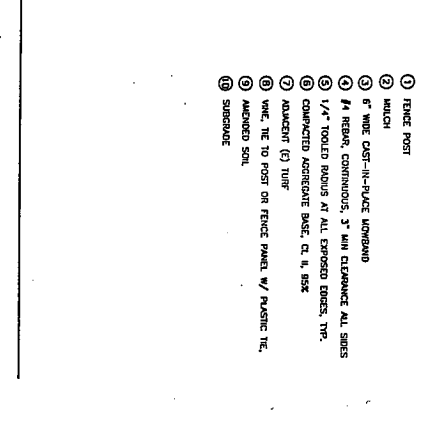
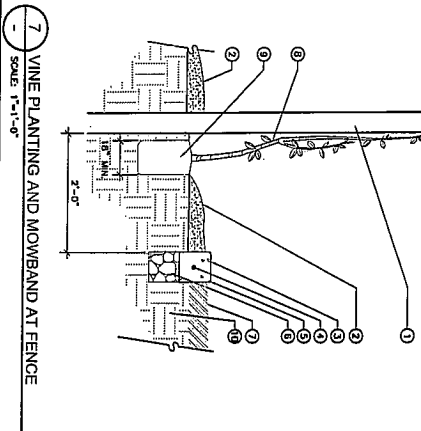
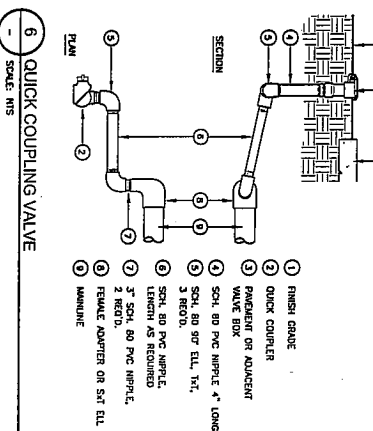
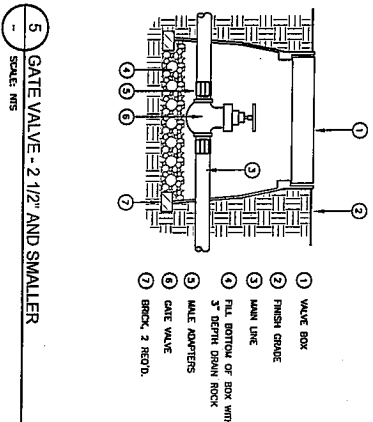
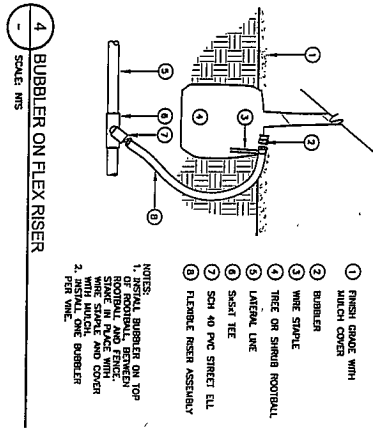
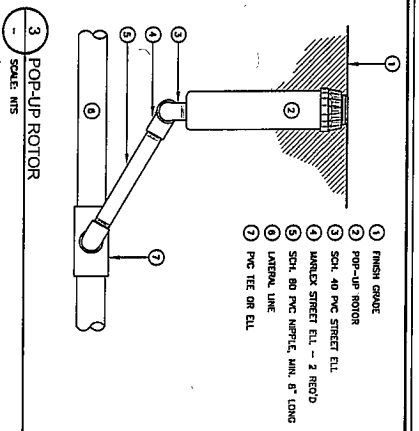
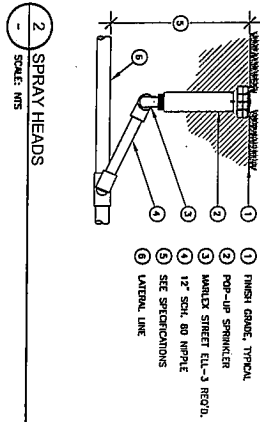
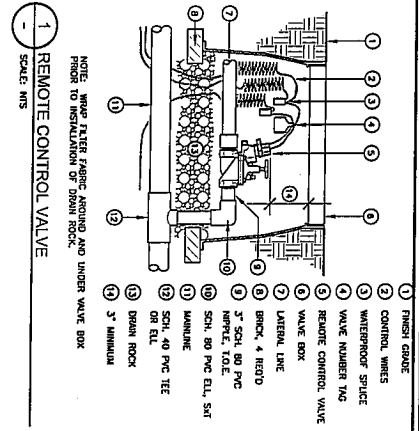

NOT FOR CONSTRUCTION

No.	Date	Description

SCALE: AS SHOWN
DATE: 7/21/2010
SHEET: 01A
SHEET: 02
SHEET: 03

IRRIIGATION & PLANTING DETAILS

L3.0

of Sheets

Lakeview Dog Park
at Lake Merritt
Oakland, CA

POA design
LANDSCAPE ARCHITECTS
4417th Street, #114
T510 465 1284
F510 465 1256

THE STATE OF CALIFORNIA
COUNTY OF ALAMEDA
I, _____, a duly Licensed Professional Engineer, do hereby certify that the above is a true and correct copy of the original as filed in my office.

DATE: _____

PROFESSIONAL ENGINEER